

THREAD PROTECTOR CLEANER

The R&R Manufacturing Thread Protector Cleaner provides cleaning of various sizes with high production in mind. The unit has a durable design, user friendly controls, minimized maintenance and is manufactured with the highest quality.



THREAD PROTECTOR CLEANER, BASE MODEL (30100.017)

STANDARD FEATURES

- Integral industrial strength vibratory motor
- Abrasive media of various shapes and sizes available
- Extra Large debris settling tanks
- Heavy Duty solvent circulation pump
- Molded tub liner for increased life

OPTIONAL FEATURES

- Pneumatic lid with additional sound damping material
- Remote monitoring

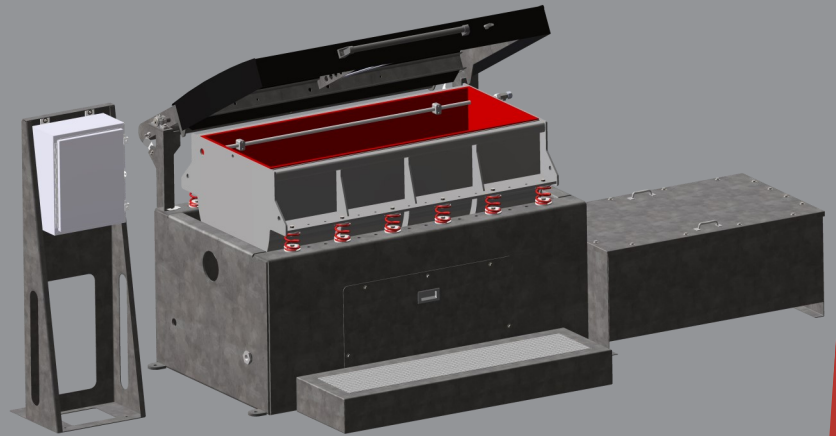

BUILDING & SERVICE REQUIREMENTS

Electrical
230/480v, 3ph, 30A, 50/60 Hz, Others by request

- Work area as per layout drawing 30100.117
- Customer responsible for all service terminations & building modifications
- Signed installation agreement, if applicable

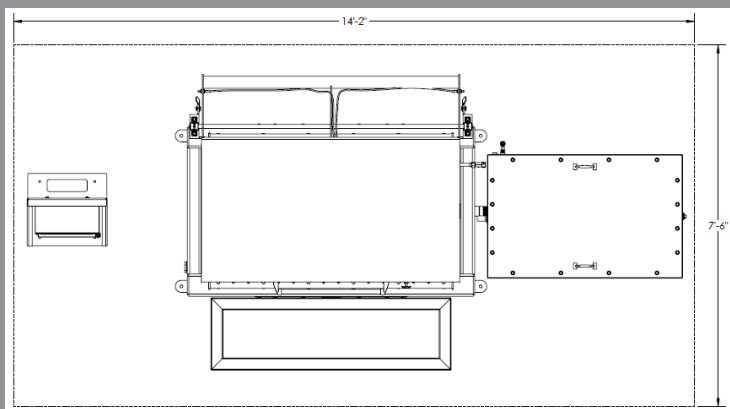

Approx Thread Protectors Per Size

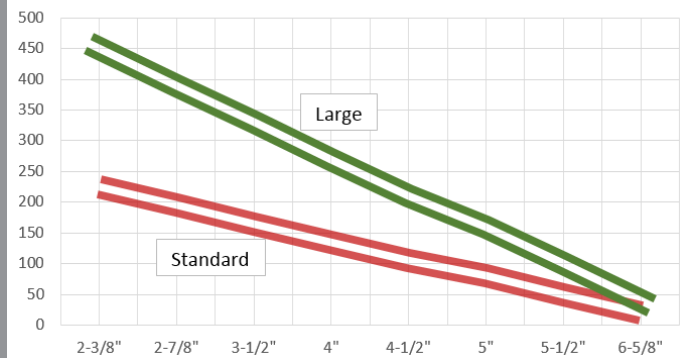

See more product information including videos, technical manual, spare parts by scanning QR code

www.rr-mfg.com

1320 Petroleum Pkwy, Broussard, LA, 70518

T 337.330.2757

F 337.330.8461

Sales@rr-mfg.com