

Tubular Cleaning Unit

Base & HD

R&R Manufacturing LLC
1320 Petroleum Pkwy
Broussard, La 70592
337.330.2757
www.RR-mfg.com
Sales@RR-mfg.com



Table of Contents

Introduction.....	3
Warranty	3
Machine specifications	4
Safety	6
Unit Setup.....	7
Unloading	7
Assembly	7
Startup	7
Layout.....	8
Operation.....	10
Setup.....	10
Cleaning Process	11
Preventative Maintenance.....	12
Daily	13
Monthly	14
Service Instructions.....	15
Lubrication guide	15
Idle wheel assembly.....	15
Drive wheel assembly.....	15
Brush housing assembly	15
Schematics	23
Pneumatic/Hydraulic	23
Electrical.....	25

Introduction

At R&R we provide over 80 years of combined experience in the engineering, R&D, manufacturing and installation of tubular cleaning units, pipe handling/cleaning equipment and all forms of conveyance systems.

In addition to the manufacturing of new equipment we also have a seasoned service staff that can perform on site repairs, maintenance and refurbishment (both mechanical and electrical). R&R also carries a variety of replacement parts for all of your tubular cleaning units as well as new and improved patent pending products exclusively provided by our company.

Warranty

R&R Manufacturing products are guaranteed for 12 months to be free from defects of material or workmanship and to perform as promised when maintained in accordance with manuals and operated under the conditions for which they were designed. Wear items such as wheels, brushes and wear tabs are excluded. Damage due to improper electrical or mechanical applications void this warranty. Use of other than genuine R&R Manufacturing replacements parts or service work performed by other than authorized R&R Manufacturing service agents will void the warranty.

Machine specifications

TUBULAR CLEANING UNIT, BASE

The R&R Manufacturing Tubular Cleaning Unit Base model provides inside and outside diameter cleaning for an array of tubular sizes and types at an affordable price. The unit has a durable design, user friendly controls, minimized maintenance and is manufactured with the highest quality.



TUBULAR CLEANING UNIT, BASE MODEL (10500.016)

STANDARD FEATURES

- Single wire brush assembly for tubular outside diameter, Qty 5, 2-1/2" Wide 10" diameter wire brushes
- Pneumatic brush assembly floating system to handle dimensional variations
- Inside diameter cleaning via rigid pipe to accommodate rattling motor or high pressure water attachment with soft impact support system to reduce possibility of tubular thread damage during conveying
- Cyclonic dust and debris collection system, Dust and debris laden air is forced into a 14 gauge steel tapered cone creating a high velocity cyclone separating particles into the debris cabinet. Fine dust is then exhausted out of the building
- 50 HP electric powered hydraulic system to efficiently perform all pipe handling operations
- Left of Right tubular loading setup
- Conveyors with 6' wheel spacing to feed tubular goods to cleaning system at adjustable feed rates
- Operator and maintenance friendly mechanical control pedestal positioned up to 25' away for maximum safety

OPTIONAL FEATURES

- Enclosures to reduce sound levels below 85db and contain dust and debris
- Dust and debris collection system with filtered exhaust. Dust is forced across cartridge style filter elements while debris falls into 55 gallon drum virtually eliminated any airborne particles
- Outside diameter extreme scale and rust removal system
- Range 3 tubular capacity
- Sucker rod capacity
- Water blasting accessory package to accept up to 40,000 psi water blasting system

BUILDING & SERVICE REQUIREMENTS

Electrical

230/480v, 3ph, 50/60 Hz, Others by request

Pneumatic

110 psi @ 175 cfm (ID Rattling)

110 psi @ 45 cfm (Non-ID Rattling)

- Work area as per layout drawing 10500.116
- Customer responsible for all service terminations & building modifications
- Signed installation agreement, if applicable



See more product information including videos, technical manual, spare parts by scanning QR code

1034 WALL ROAD, BROUSSARD, LA, 70518

T 337.330.2757 F 337.330.8461

WWW.RR-MFG.COM

TUBULAR CLEANING UNIT, HD

The R&R Manufacturing Tubular Cleaning Unit HD model provides inside and outside diameter cleaning for an array of tubular sizes and types with high production in mind. The unit has a durable design, user friendly controls, minimized maintenance and is manufactured with the highest quality.



TUBULAR CLEANING UNIT, HD MODEL (10800.016)

STANDARD FEATURES

- Two wire brush assemblies for tubular outside diameter, Qty 12, 2-1/2" Wide 10" diameter wire brushes
- Pneumatic brush assembly floating system to handle dimensional variations
- Inside diameter cleaning via rigid pipe to accommodate rattling motor or high pressure water attachment with soft impact support system to reduce possibility of tubular thread damage during conveying
- Two cyclonic dust and debris collection system, Dust and debris laden air is forced into a 14 gauge steel tapered cone creating a high velocity cyclone separating particles into the debris cabinet. Fine dust is then exhausted out of the building
- 50 HP electric powered hydraulic system to efficiently perform all pipe handling operations
- Left of Right tubular loading setup
- Conveyors with 6' wheel spacing to feed tubular goods to cleaning system at adjustable feed rates
- Operator and maintenance friendly electric control pedestal positioned up to 25' away for maximum safety

OPTIONAL FEATURES

- Enclosures to reduce sound levels below 85db and contain dust and debris
- Dust and debris collection system with filtered exhaust. Dust is forced across cartridge style filter elements while debris falls into 55 gallon drum virtually eliminated any airborne particles
- Outside diameter extreme scale and rust removal system
- Range 3 tubular capacity
- Water blasting accessory package to accept up to 40,000 psi water blasting system

BUILDING & SERVICE REQUIREMENTS

Electrical
230/480v, 3ph, 50/60 Hz, Others by request

Pneumatic
110 psi @ 175 cfm (ID Rattling)
110 psi @ 45 cfm (Non-ID Rattling)

- Work area as per layout drawing 10800.116
- Customer responsible for all service terminations & building modifications
- Signed installation agreement, if applicable



See more product information including videos, technical manual, spare parts by scanning QR code

1034 WALL ROAD, BROUSSARD, LA, 70518

T 337.330.2757 F 337.330.8461

WWW.RR-MFG.COM

Safety

To ensure this quality product is safely and correctly utilized, all instructions within this manual must be read and understood prior to equipment start-up. Be aware of all safety labels on machinery. If you do not understand any of the safety instructions contact your supervisor or product supplier immediately!

Compliance with safety standards, including federal, state and local codes or regulations is the responsibility of the purchaser(s). A safety study should be made of the products application by the purchaser(s). It is the purchaser's responsibility to provide any additional guards, safety labels or other safety equipment deemed necessary based on this safety study.

The information contained in this safety manual is correct at the time of printing. Due to the continuing development of product lines, changes in specifications are inevitable. The company reserves the right to implement such changes without prior notice.

If you suspect fire hazards, safety hazards, dangers towards health or any other job safety concerns, consult your federal, state or local codes.

Inspect equipment for safety labels. Make sure personnel are aware of and follow safety instructions. Maintain an orderly environment in the vicinity of the conveyor at all times. Clean up spilled materials or lubricants immediately. All personnel shall be instructed regarding the necessity for continuous care and attention to safety during the operation. They must be trained to identify and immediately report all unsafe conditions or practices relating to the conveyor and its operation. Know your company's machine specific Lockout / Tagout procedure. Do not perform maintenance until electrical disconnect has been turned off! Replace all safety devices, guards and guarding prior to equipment start-up.

All electrical installations and wiring shall conform to federal, state and local codes

Control stations should be so arranged and located that the operation of the affected equipment is visible from them. Control stations shall be clearly marked or labeled to indicate the function controlled.

Remotely and automatically controlled products, and products where operator stations are not manned or are beyond voice or visual contact from drive areas, loading areas, transfer points and other potentially hazardous locations on the conveyor path not guarded by location, position or guards shall be furnished with emergency stop buttons, pull cords, limit switches or similar emergency stop devices. Where the design, function and operation of such conveyor clearly is not hazardous to personnel, an emergency stop device is not required. The emergency stop devices shall be installed so that they cannot be overridden from other locations.

Only trained, qualified personnel shall be permitted to operate a machine. Training shall include instruction in operation under normal conditions and emergency situations.

The product shall be used to transport only a load that it is designed to handle safely.

It is the responsibility of the purchaser of this unit to train operating personnel in the proper manner of operation. It is furthermore understood that R&R Manufacturing assumes no responsibility for injury, disability, or death resulting from improper operation, removal, or bypassing of any electrical or mechanical safety devices incorporated in the design and manufacturing of this product.

The proper clothing for the job is to be worn at all times. A number of types of protective equipment are available which can help you to avoid injury.

Unit Setup

Unloading

R&R Manufacturing equipment is carefully inspected and packed before leaving our factory. The transportation company assumes full responsibility for safe delivery of this equipment. Visible damage or loss should be noted on freight bill and signed by person making delivery. A freight claim should be filed immediately with the transportation company. If damage is unnoticed or concealed until equipment is unpacked, notify the transportation company immediately and tell them you want to file a concealed damage claim. This must be done within fifteen (15) days after delivery was made. Be sure to retain all packing material and cartons.

WARNING: Installation of this equipment should be performed only by qualified personnel with consideration for local, state and federal regulations.

Adjustments and service work should be performed only by a qualified service technician. Service & Installation is available through R&R Manufacturing.

Assembly

1. Position frames and auxiliary equipment as indicated and loosely bolt together
2. Connect all hydraulic, pneumatic and electrical connections as per schematics.
3. Rough align the machine axially by running a string from end to end and checking the frame center to the string along the frame at wheel support members.
4. Level the machine setting the distance as indicated below using the leveling feet.
 - a. The top of the C-Channel to top of the rack is 7.0"
 - b. The elevation tolerance is $\pm 1/8$ "
5. Check axial alignment.
 - a. The axial alignment tolerance is $\pm 1/8$ "
6. Recheck elevation and adjust as necessary
7. Tighten frame connecting bolts.
8. Anchor feet to concrete foundation. A minimum of 4" thick concrete is required but local soil conditions may dictate otherwise.
9. Tighten anchor bolts as per manufacturer's recommendation.

Startup

1. Ensure all hydraulic, pneumatic, and electrical lines are tight and secure.
2. Ensure hydraulic tank is filled with oil at the correct level
 - a. AW32 weight oil is recommended in a temperate climate
 - b. Local climate may dictate otherwise
3. Ensure electrical motors are spinning as indicated on pump.
4. Turn hydraulic power supply on (3) and ensure:
 - a. Stop button is working
 - b. Dust collector off/on is working
 - c. The system pressure is 1800 PSI
 - d. Hydraulic oil low level switch functions properly by shutting down motor during a low oil situation.
 - e. Each hydraulic and pneumatic valve is operating the correct function
 - i. Function operating speed has been set at the factory, however minor adjustments may be made during start up.

Layout

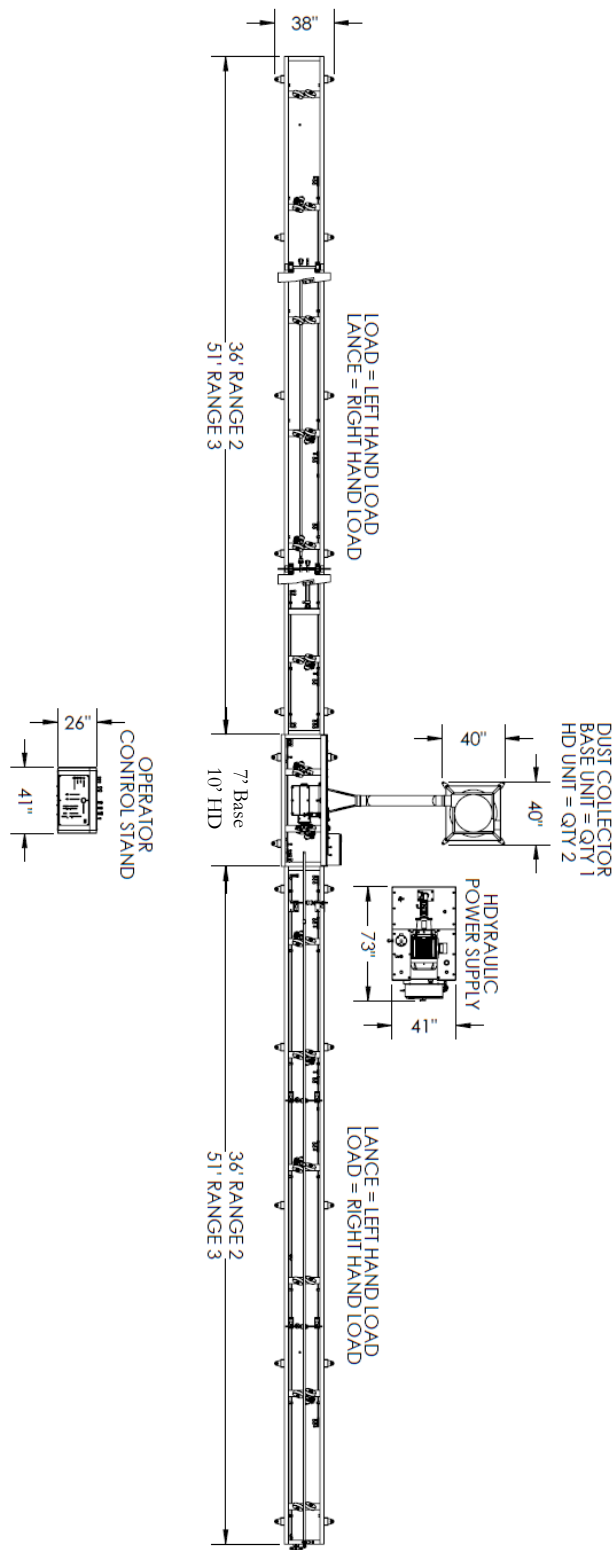

The layout below is for reference only. Most facilities have unique challenges that this layout does not address. Please contact R&R Manufacturing for assistance. R&R Manufacturing is not responsible for issues arising from layout design.

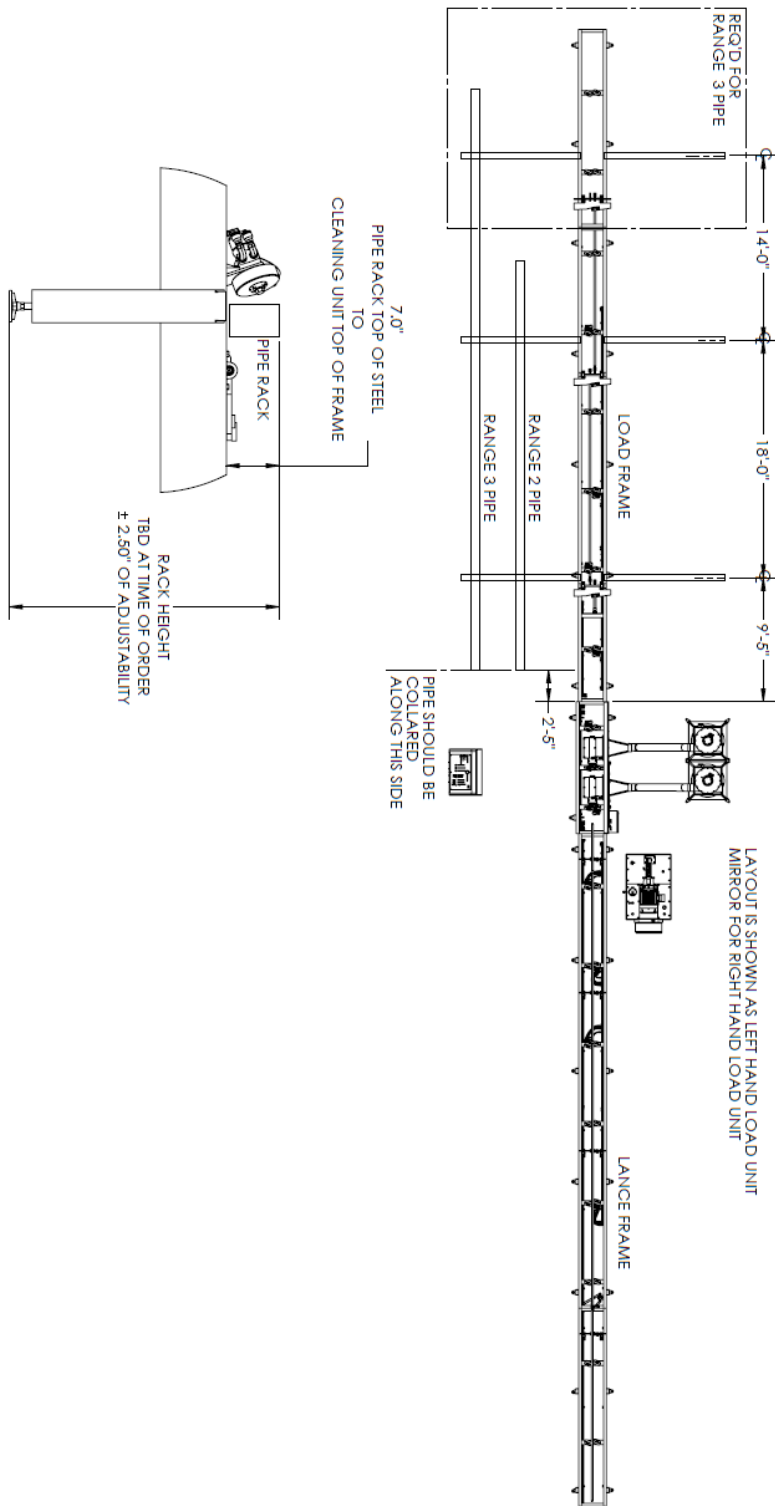

Operation

Setup

The steps below are typical of most scenarios. Each action is indicated by a number in parenthesis (#) which correlates to the control drawing below. Actual control panel layout and functionality may vary.

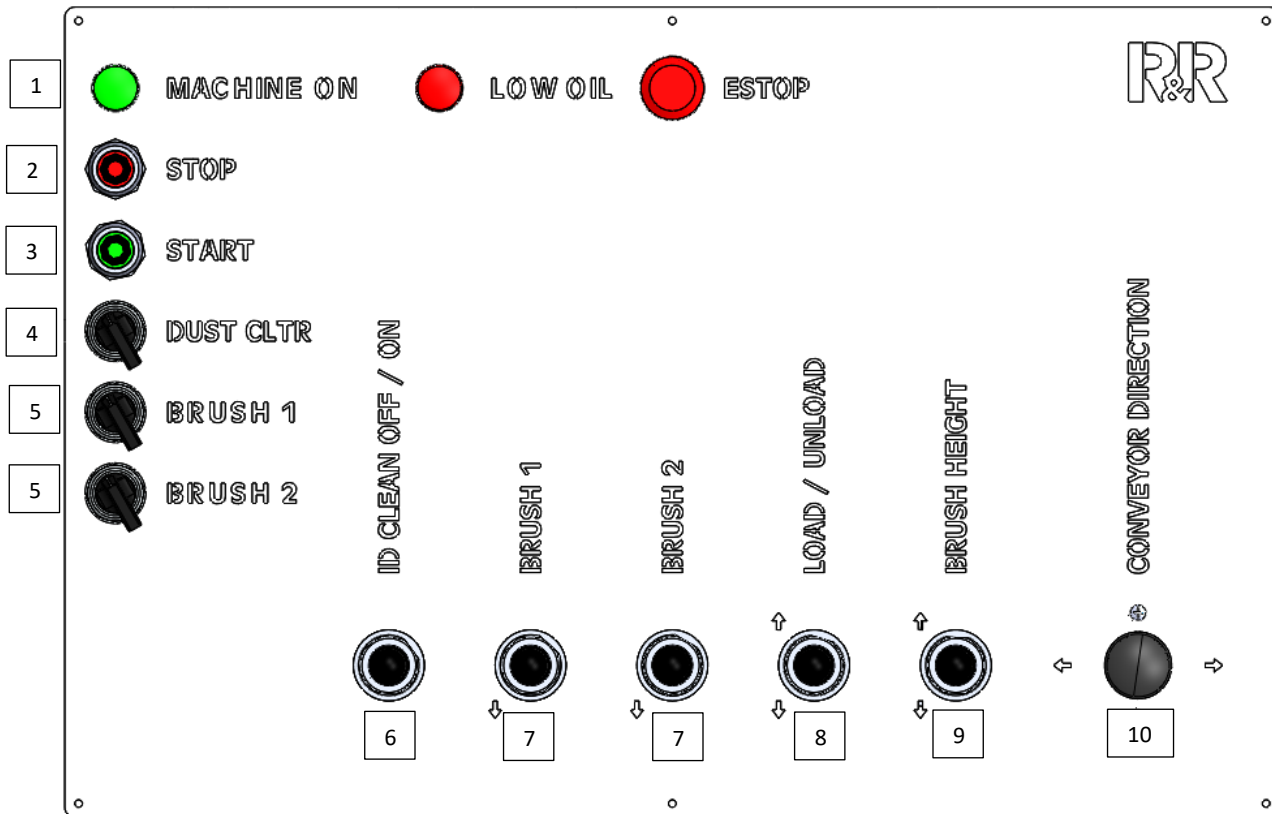

1. Turn machine on (3), green power light (1) will light
2. Raise brush housing to the highest position (9).
3. Turn OD brush motor(s) on (5).
4. Load pipe onto unit (8).
5. Move pipe (10) tube body (not the upset) under brush.
6. Engage the brush(es) (7).
7. Set brush housing height (9). Brush frame should be level when engaging the pipe.
8. Disengage (7) the brushes and power off (5).
9. Select and install desired ID cleaning head (H2O blast nozzle/rattling head).
10. Move pipe (10) a few inches away from ID cleaning head and set the front lance support height appropriately.
11. Move the pipe (10) down the machine adjusting mid & rear lance supports as necessary.
12. Move pipe to starting position and commence cleaning operations.

Cleaning Process

1. Ensure that all preventative maintenance is up to date and the all safety procedures are followed.
2. Load the pipe (8) with the box facing the operator.
3. Turn OD brush(es) motor on (5).
4. Turn dust collector on (4) if cleaning by dry method; do not use during wet operations.
5. Move the pipe forward (10) at the desired speed by throttling joystick.
6. Engage the brush(es) (7) as the pipe upset is under the brush.
 - a. Do not engage the brush(es) (7) before the pipe is under the brush as this may cause significant premature wear to the brush.
7. Engage the ID clean (6):
 - a. During dry cleaning: rattling motors should be turned on after the cutting heads clear any internal threads.
 - b. During wet cleaning: spray heads may be used to clean internal threads.
8. Disengage OD brush(es) (7) after pipe passes brushes.
9. Reverse pipe direction (10) before the ID cleaning head reaches the end of the pipe. Careful consideration if using rattling head as pieces may break off if it comes out of the pipe.
10. Engage OD brush(es) (7) as pipe upset is under the brush.
11. Disengage ID cleaning head (5) with consideration for 7a & 7b.
12. Disengage OD cleaning brush(es) (7).
13. Load/Unload next pipe joint (8).
14. Repeat steps 1-12.

Preventative Maintenance

- All maintenance, including lubrication and adjustments, shall be performed only by qualified and trained personnel.
- It is important that a maintenance program be established to insure that all components are maintained in a condition which does not constitute a hazard to personnel.
- When a unit is stopped for maintenance purposes, starting devices or powered accessories shall be locked or tagged out in accordance with a formalized procedure designed to protect all persons or groups involved with the machine against an unexpected start.
- Replace all safety devices and guards before starting equipment for normal operation.

Daily



TCU, Base Daily Preventative Maintenance

Company _____
 Location _____
 Serial No. _____
 Week _____

Perform each task at the start of each shift or a 24 hour period
 Initial in each block after the task is complete and follow company procedures
 Additional information can be found throughout the operations manual

Day	Grease all points: -Idle wheel assembly -Brush shaft bearings -Brush frame bearings -Paddle bearings	Inspect Wheel Stations: -Wheels for excessive wear -Loose or missing hardware -Hydraulic leaks	Inspect Load/Unload System -Wear pads for excessive wear -loose or missing hardware	Inspect Brush Housing -Excessive brush wear -Excessive vibration -Loose or missing hardware	Inspect Hydraulic/Pneumatic System -Leaks & loose fittings -Check oil lubrication level -Worn hoses -Correct system pressure	Inspect Dust Collection System -Empty debris bin -Ensure fan housing is clear of debris
1						
2						
3						
4						
5						
6						
7						

Comments:

R&R Manufacturing
 1034 Wall Road
 Broussard, La, 70518
 Sales@rr-mfg.com
 337.330.2757

Monthly

		TCU, Base Monthly Preventative Maintenance											
Company _____ Location _____ Serial No. _____ Week _____													
Record data for each task Additional information can be found throughout the operations manual													
Task	Month												
	1	2	3	4	5	6	7	8	9	10	11	12	
All Task/Check points on daily preventative maintenance													
Hydraulic System													
System Pressure (compare to calibrated pressure gauge)													
Return filter pressure (green/yellow/red)													
Fluid particulate count													
Sample oil and send for analysis (annually)													
Fluid flow (GPM)													
Record operating temperature (unit must be operating for 2 hrs)													
Mechanical Systems													
Cycle brush plate up and down completely 5 times													
Visually check machine alignment and level													
Check for excessive component wear or corrosion													
Electrical Systems													
Record motor amp draw													
Grease motor bearing (0.47 oz) (annually)													
Tighten all electrical connections (high voltage side)													
Check for excessive vibration and heat													
Check PLC/sensor cleanliness and hardware for loose components													
Manually trip motor overload protection													
Pneumatic System													
Inspect filter													
Ensure autodrain is functioning properly													
Brush pressure setting, adjust as necessary and record settings													
Check lubrication setting (level 4)													
Check for leaks and hardware for loose components													
Comments:													

R&R Manufacturing
 1034 Wall Road
 Broussard, La, 70518
 Sales@rr-mfg.com
 337.330.2757

Service Instructions

Lubrication guide

The application of grease and corrosion inhibitors are vital to operation of the unit. The table below details the appropriate lubricant grade during any service work.

Bronze bearings	Chevron SRI NLGI No. 2
Idle wheel hex head bolt	Loctite Marine Grade Anti-Seize, 34026
Motor shaft/coupling interface	Loctite Marine Grade Anti-Seize, 34026
Brush shaft bearing	Chevron SRI NLGI No. 2
Electric Motor	Chevron SRI NLGI No. 2
All other hardware not listed above	Loctite 242
All NPT connections	Loctite 567
All electrical connection	Loctite Silicon Dielectric grease, 30536

Idle wheel assembly

1. Lock out / Tag out unit as per company procedures.
2. Remove worn or damage idle wheel assembly components and replace parts as necessary.
3. Grease components as specified in lubrication guide.
4. Start machine as per Lock Out / Tag Out procedures.
5. Load and locate pipe so that the pipe tube body is over the idle wheel.
6. Adjust the wheel upwards so that the wheel slightly makes contact with the pipe.
7. Tighten to 78 ft/lbs.

Drive wheel assembly

1. Lock out / Tag out unit as per company procedures.
2. Remove worn or damage motor wheel assembly components and replace parts as necessary.
3. Grease components as specified in lubrication guide.
4. Start machine as per Lock Out / Tag Out procedures.

Brush housing assembly

Visit www.rr-mfg.com, and click on videos for an instructional video

1. Raise brush housing back plate to the highest position.
2. Insert brush changeover rack.
3. Lower brush housing back plate until the brush frame makes contact with changeover rack.
4. Lock out / Tag out unit as per company procedures.
5. Remove bearing bolts.
6. Loosen motor coupling and slide brush shaft coupling towards brushes.
7. Start machine as per Lock Out / Tag Out procedures.
8. Raise brush housing back plate to the highest position with brush assembly remaining in place.
9. Remove worn or damage brush housing assembly and replace parts as necessary.
10. Locate brush assembly back on changeover rack and lower brush housing frame.
11. Lock out / Tag out unit as per company procedures.
12. Install bearing bolts to 23 ft/lbs and shaft coupling.
13. Turn brush on and ensure no vibration, adjust as necessary.

Parts

Brush Plate Assembly

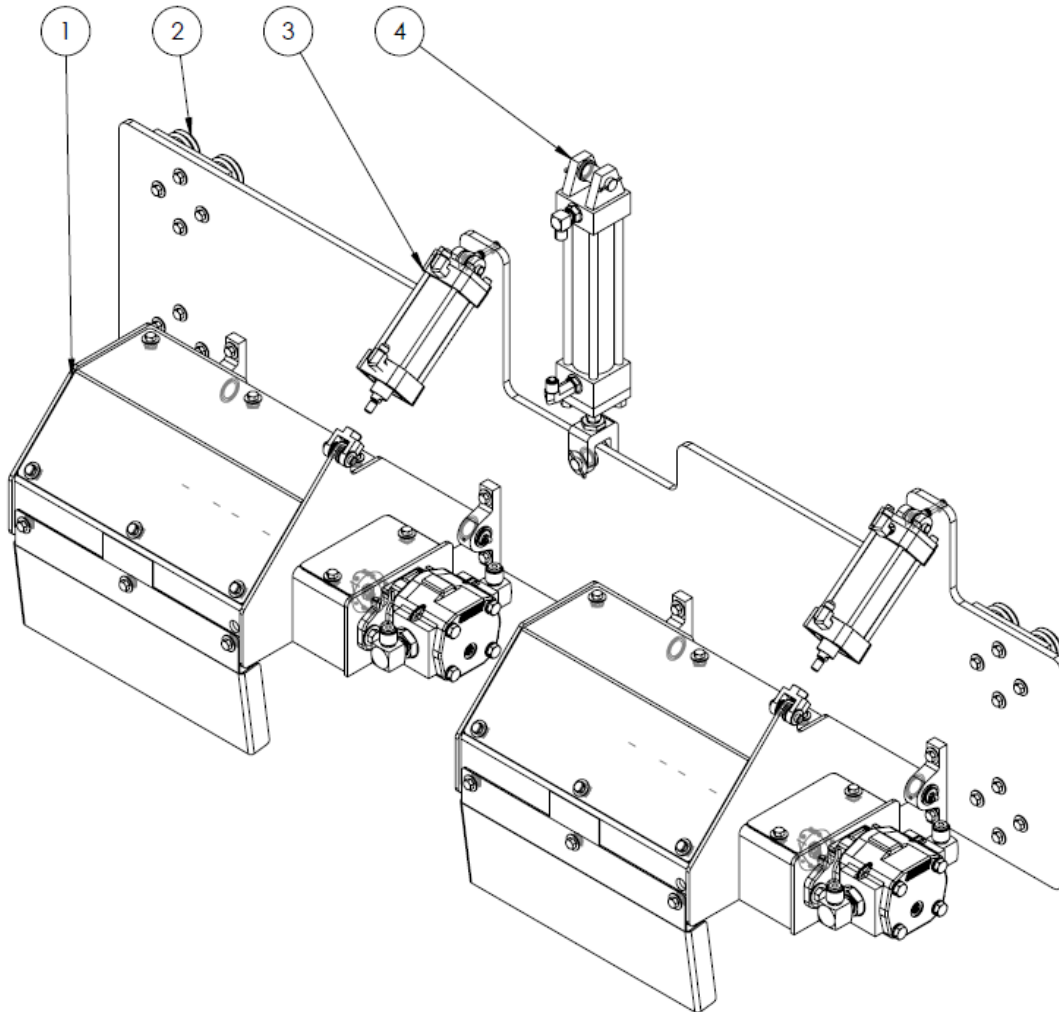

ITEM NO.	PART NO.	DESCRIPTION
1	1010-029	OD BRUSH ASSEMBLY
2	50098	WHEEL CARRIAGE ASSEMBLY
3	50099	CYLINDER, AIR, BRUSH FRAME LIFT
4	50022	CYLINDER, HYD, BRUSH PLATE LIFT

Brush Assembly

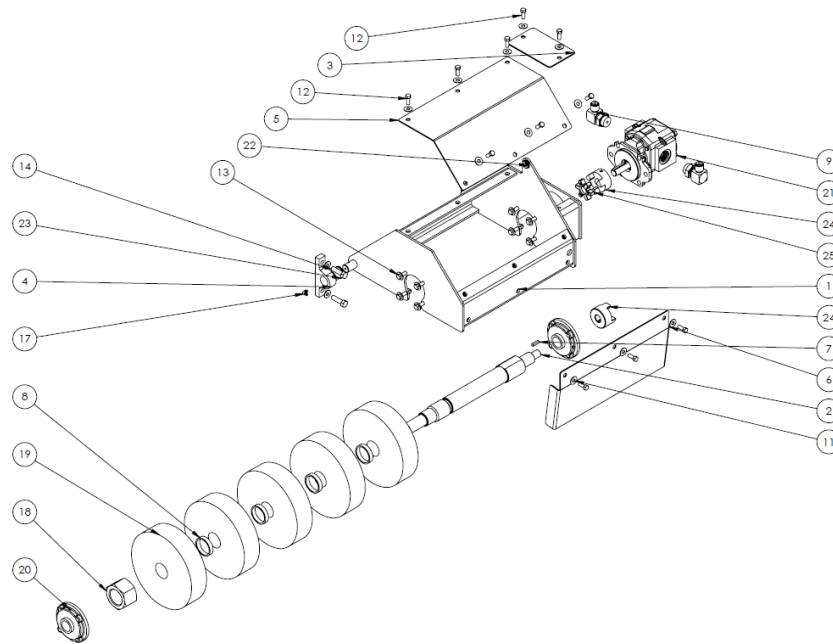

ITEM NO.	PART NO.	DESCRIPTION
1	1020-036	BRUSH FRAME
2	1050-001	BRUSH SHAFT
3	1050-005	BRUSH FRAME
4	1050-006	BRUSH FRAME BEARING BLOCK
5	1050-007	BRUSH FRAME COVER
6	1050-008	BRUSH GAURD
7	1050-017	BRUSH SHAFT KEYWAY
8	1050-021	BRUSH SPACER
9	20120	HYDRAULIC FITTING
10	30000	FLAT WASHER, 0.5000
11	30007	FLAT WASHER, 0.3750
12	30662	HEX BOLT, 0.3750-16 X 1
13	30686	HEX BOLT, 0.3750-16 X 1.75
14	31182	HEX BOLT, 0.5000-13 X 1.75
15	33976	HEX NUT, 0.3750-16
16	33992	HEX NUT, 0.5000-13
17	34075	GREASE ZERK
18	34084	BRUSH NUT
19	50002	WIRE WHEEL
20	50014	BEARING
21	50026	BRUSH MOTOR
22	50080	BUSHING
23	50082	BUSHING
24	50086	COUPLING HUB
25	50087	SPIDER

Lance Support, Front

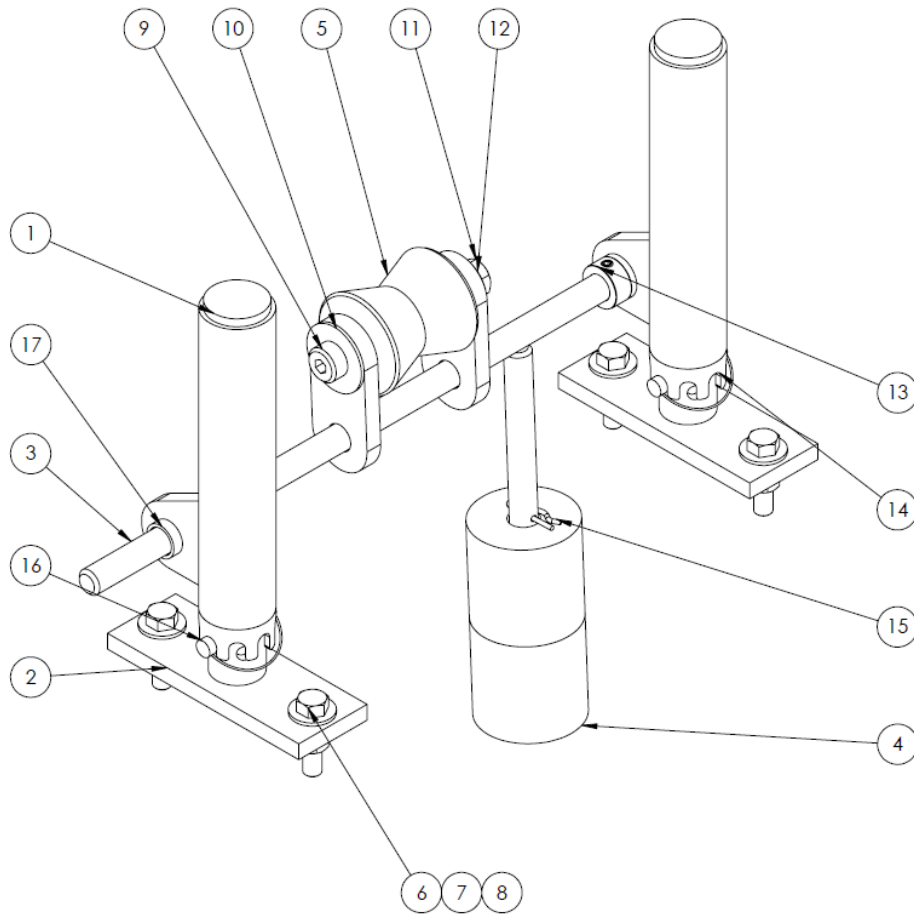

ITEM NO.	PART NO.	DESCRIPTION
1	1020-008	LANCE, SUPPORT, FRONT, POST
2	1020-009	LANCE, SUPPORT, INNER POST
3	1020-029	LANCE, SUPPORT, BAR SUPPORT
4	1070-003	LANCE SUPPORT COUNTERWEIGHT
5	1070-012/50081	LANCE ROLLER WITH BUSHING
6	30000	WASHER, FLAT 0.5000
7	31190	BOLT, HEX 0.5000-13 X 2
8	33992	NUT, HEX 0.5000-13
9	34093	BOLT, SHOULDER, 0.7500 NC X 4.5" LG
10	30016	WASHER, FLAT 0.7500
11	34008	NUT, HEX 0.6250-11
12	30014	WASHER, FLAT, 0.6250
13	50088	SET COLLAR, SET SCREW, 0.7500
14	1070-032	ADJUSTMENT NUT
15	34101	HAIRPIN
16	50247	PIN
17	50081	BUSHING, FLANGED, 3/4"
18		

Lance Support, Rear

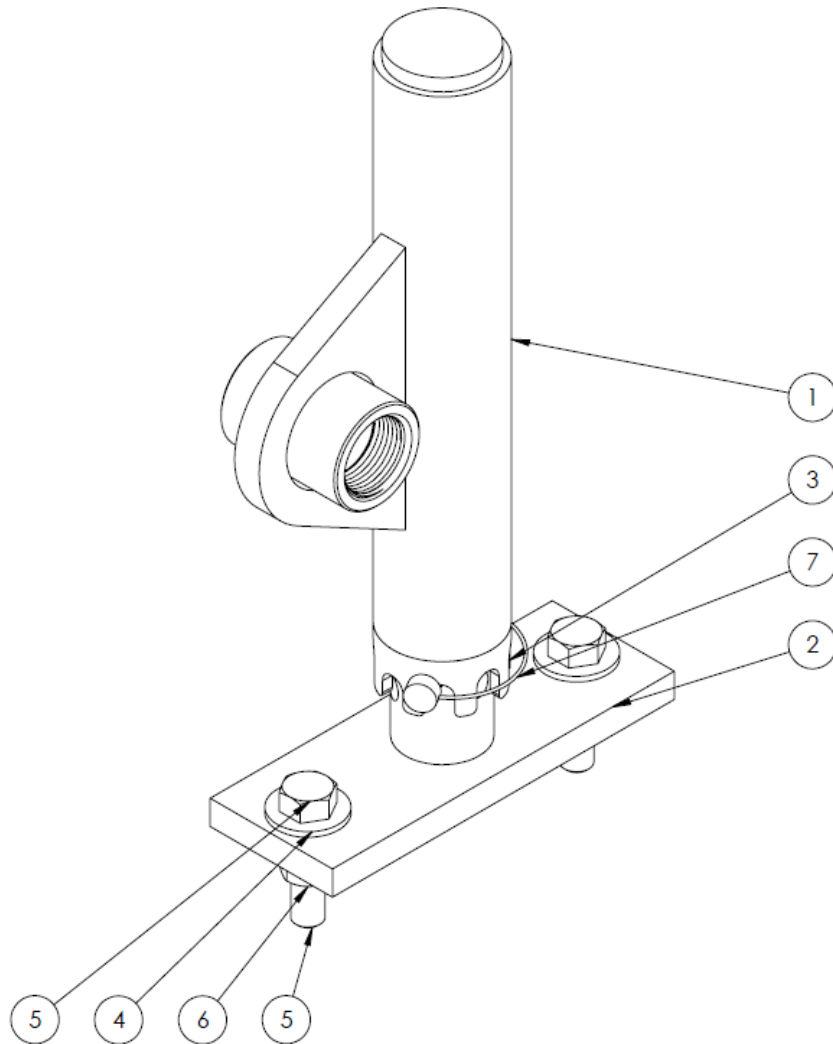

ITEM NO.	PART NO.	DESCRIPTION
1	1020-033	REAR LANCE SUPPORT, OUTER TUBE
2	1020-048	LANCE INNER POST
3	1070-032	ADJUSTMENT NUT
4	30000	WASHER, FLAT, 0.5000
5	31190	BOLT, HEX, 0.5000 NC, 2" LG
6	33992	NUT, HEX, 0.5000 NC
7	50247	PIN

Drive Wheel Station

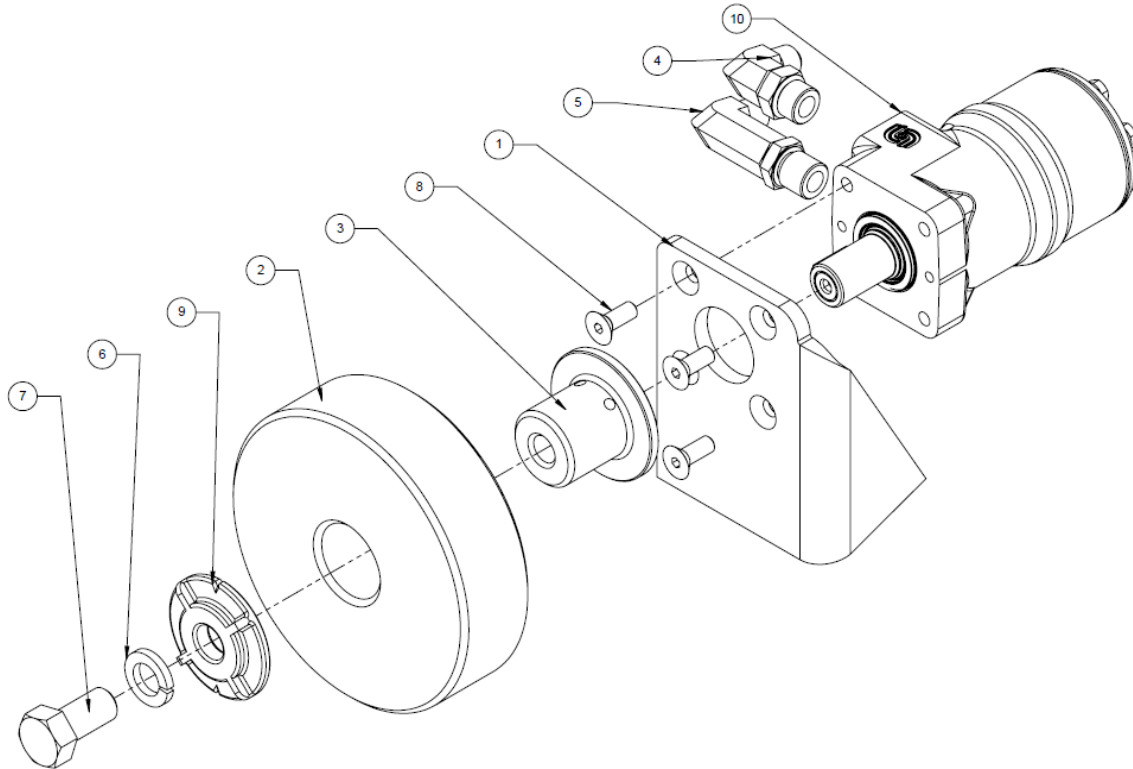

ITEM NO.	PART NO.	DESCRIPTION
1	1060-003	DRIVE PEDESTAL
2	1060-006	WHEEL
3	1060-007	DRIVE HUB
4	20044	HYD. FITTING, 90°
5	20045	HYD. FITTING, 90°, X-LONG
6	30051	LOCK WASHER, 0.75"
7	31757	HEX BOLT, 0.75 – 10 X 1.5" LG, SS
8	34083	FLAT SOCKET HEAD BOLT, 0.375 – 16 X 1.0"
9	34092	WASHER
10	-	HYD. MOTOR, PART NUMBER VARIES BY MFR DATE, CALL FOR PART NUMBER

Idle Wheel Station

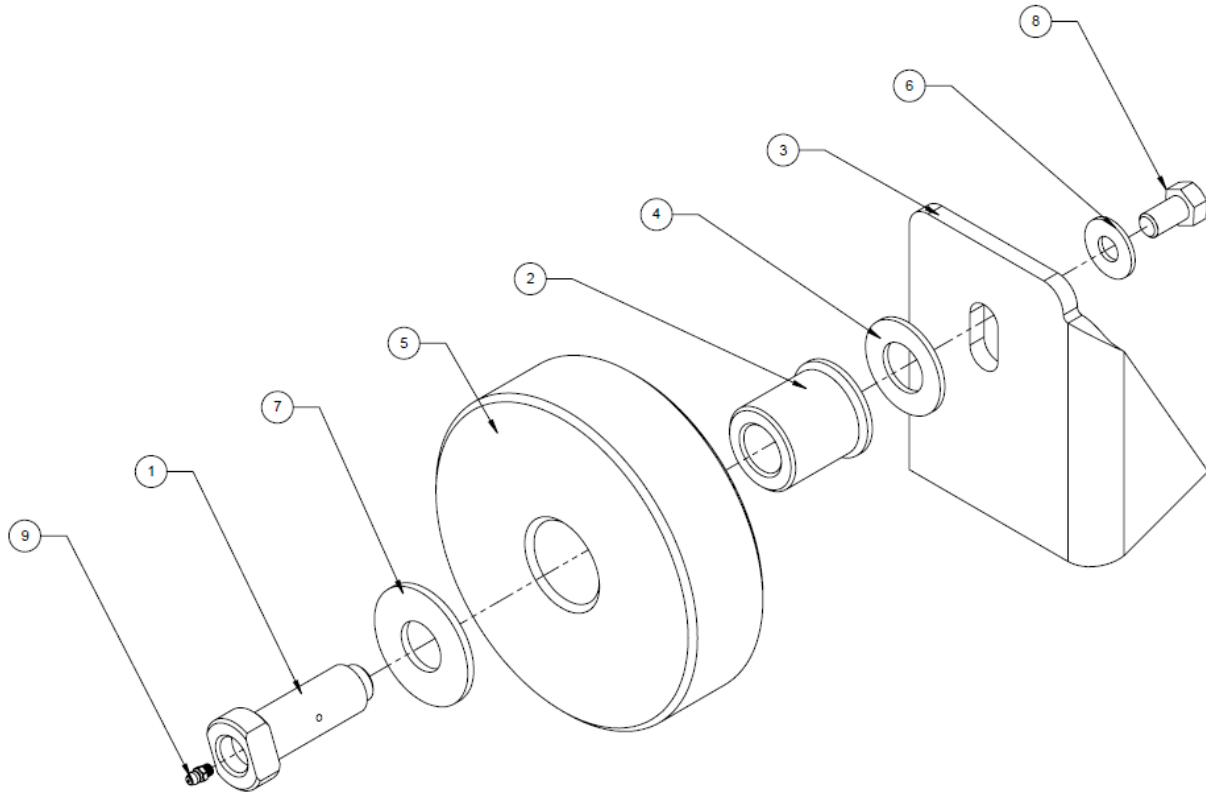

ITEM NO.	PART NO.	DESCRIPTION
1	1060-001	SHOULDER BOLT
2	1060-002	WHEEL BEARING
3	1060-004	IDLE PEDESTAL
4	1060-005	THRUST WASHER
5	1060-006	WHEEL
6	30000	FLAT WASHER, 0.5"
7	30020	FLAT WASHER, 1.0"
8	31157	HEX BOLT, 0.5-13 X 0.875" SS
9	34076	GREASE ZERK

Load/Unload Paddle

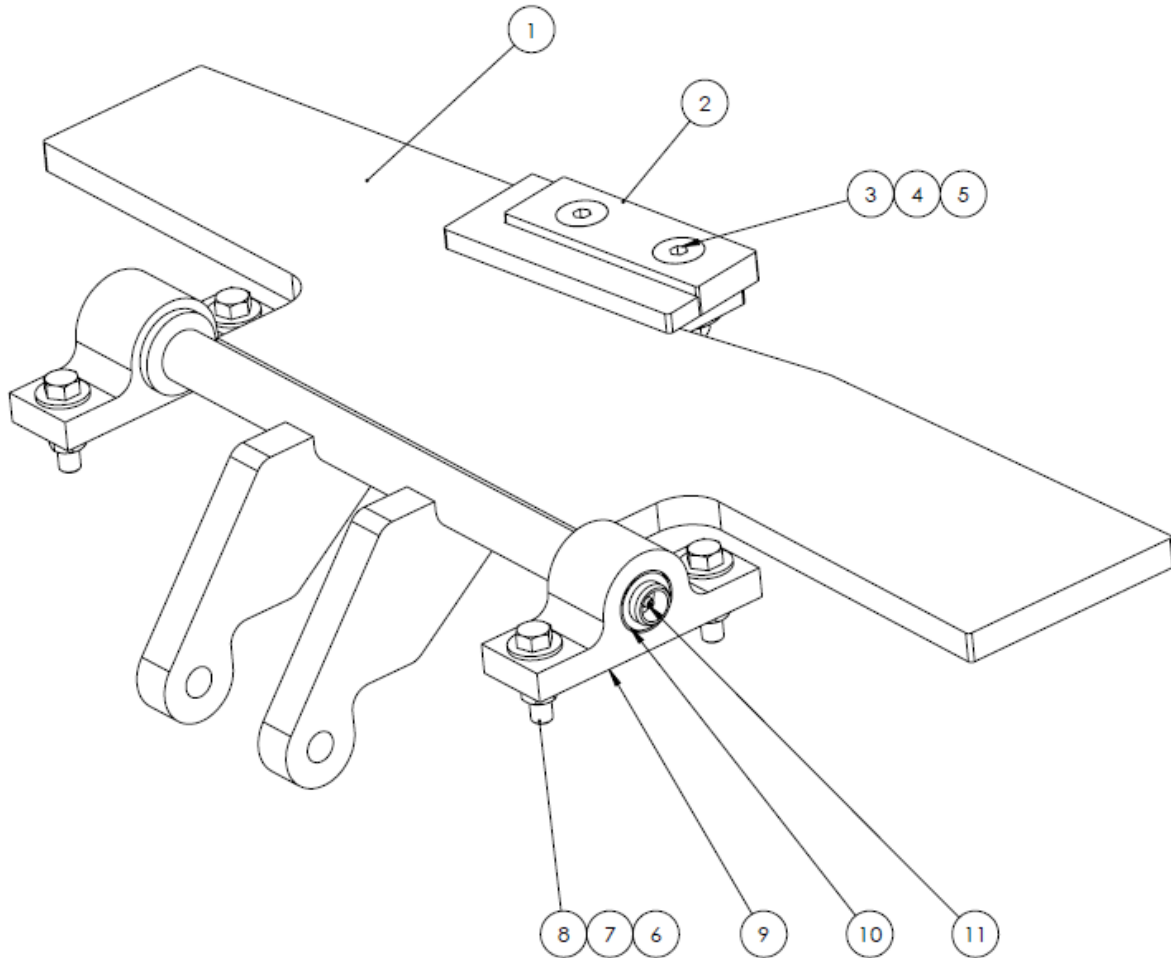

ITEM NO.	PART NO.	DESCRIPTION
1	1020-027	PADDLE
2	1045-010	WEAR TAB
3	34079	FLAT SOCKET HEAD BOLT, 0.625 - 11 X 2.5"
4	30014	FLAT WASHER, 0.625"
5	34008	HEX NUT, 0.625 - 11
6	30000	FLAT WASHER, 0.5"
7	33992	HEX NUT, 0.5-13
8	31190	HEX BOLT, 0.5-13 X 2"
9	1045-001	BEARING HOUSING
10	1045-004	BEARING
11	34076	GREASE ZERK
-	50022	HYDRAULIC CYLINDER
-	50044/50053	CLEVIS AND PIN
-	50054	REAR CYLINDER MOUNTING BRACKET

Schematics

The schematics below is a general guideline, consult R&R Manufacturing for machine specific schematics.

Pneumatic/Hydraulic

TCU, Base

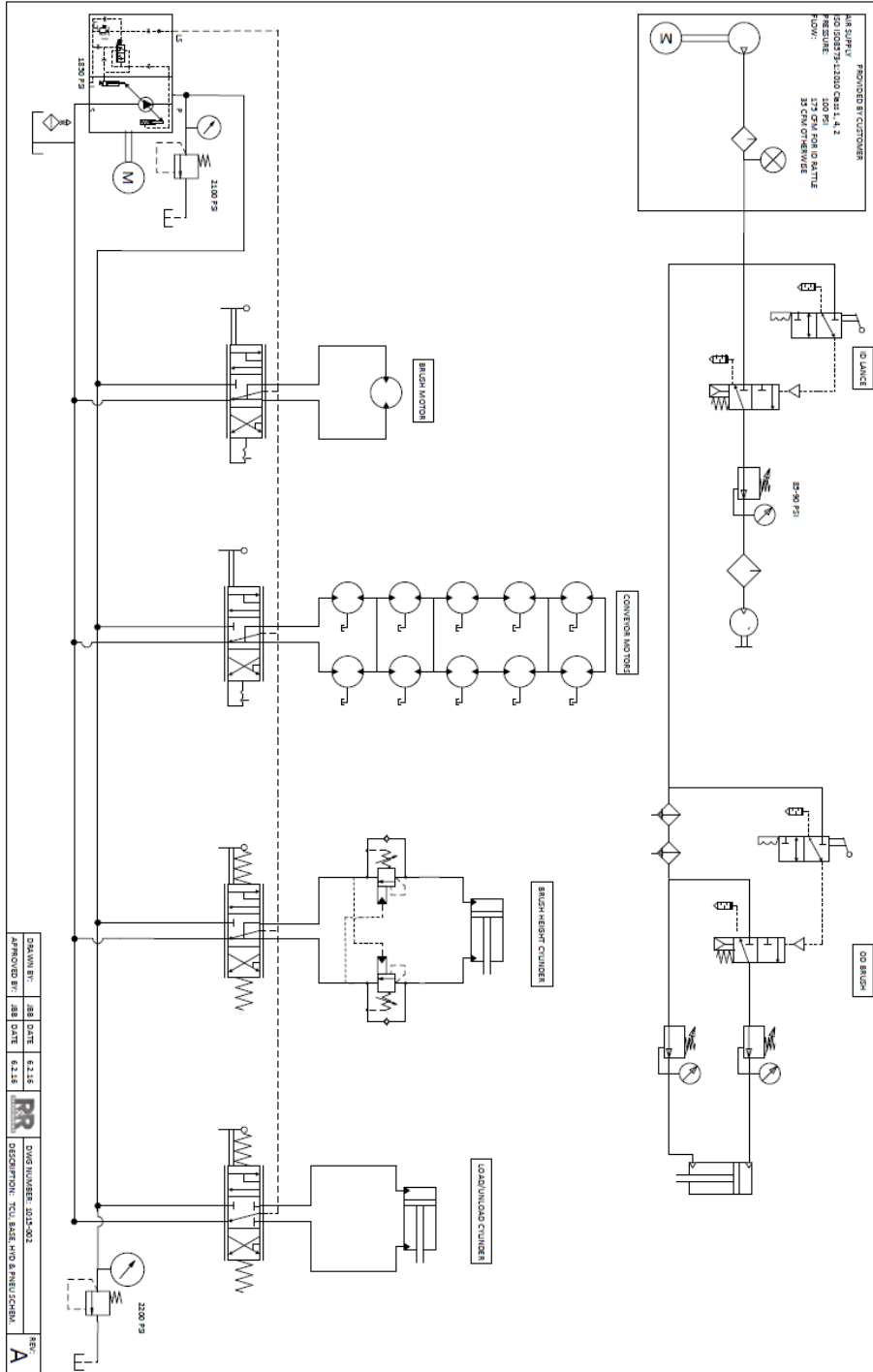

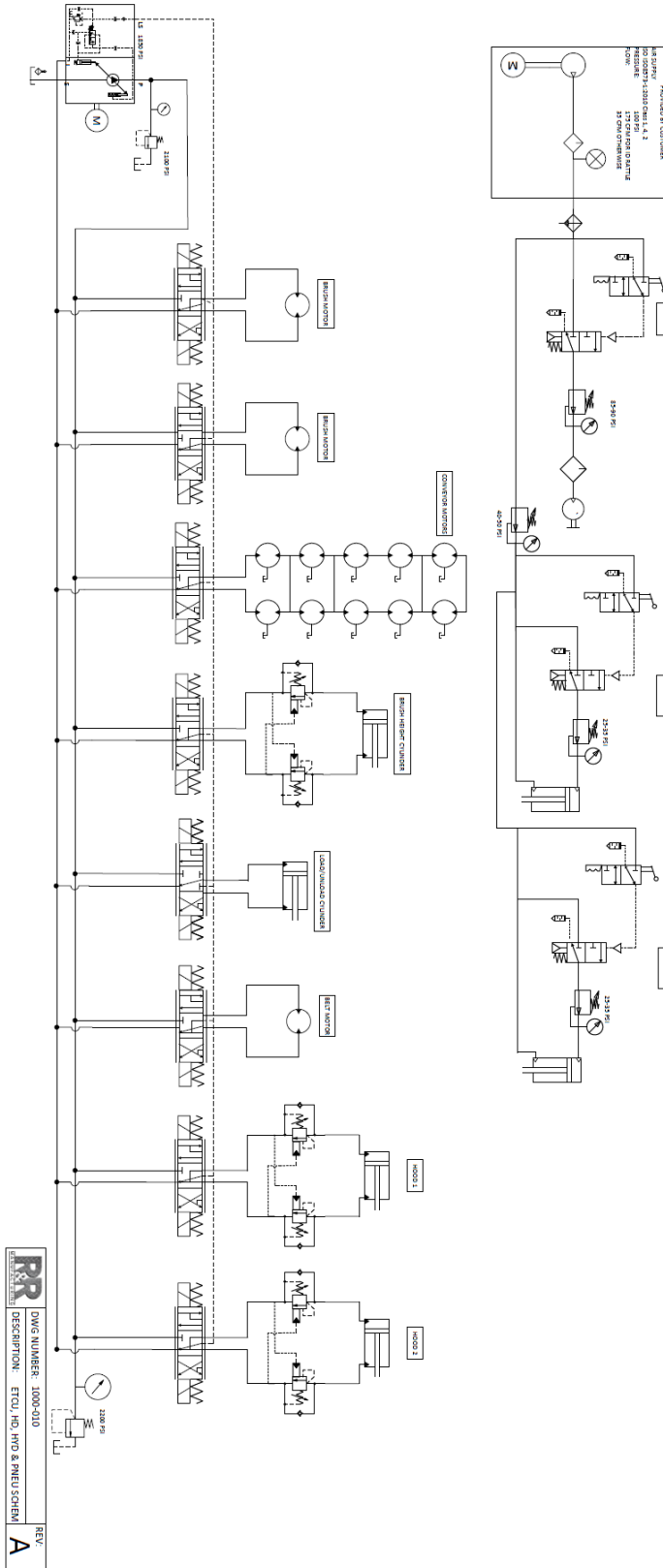

RR REV. 01	DWG. NUMBER: 1000-010
	DESCRIPTION: ETOU, HD, HD & MENU SCREEN
REV	A

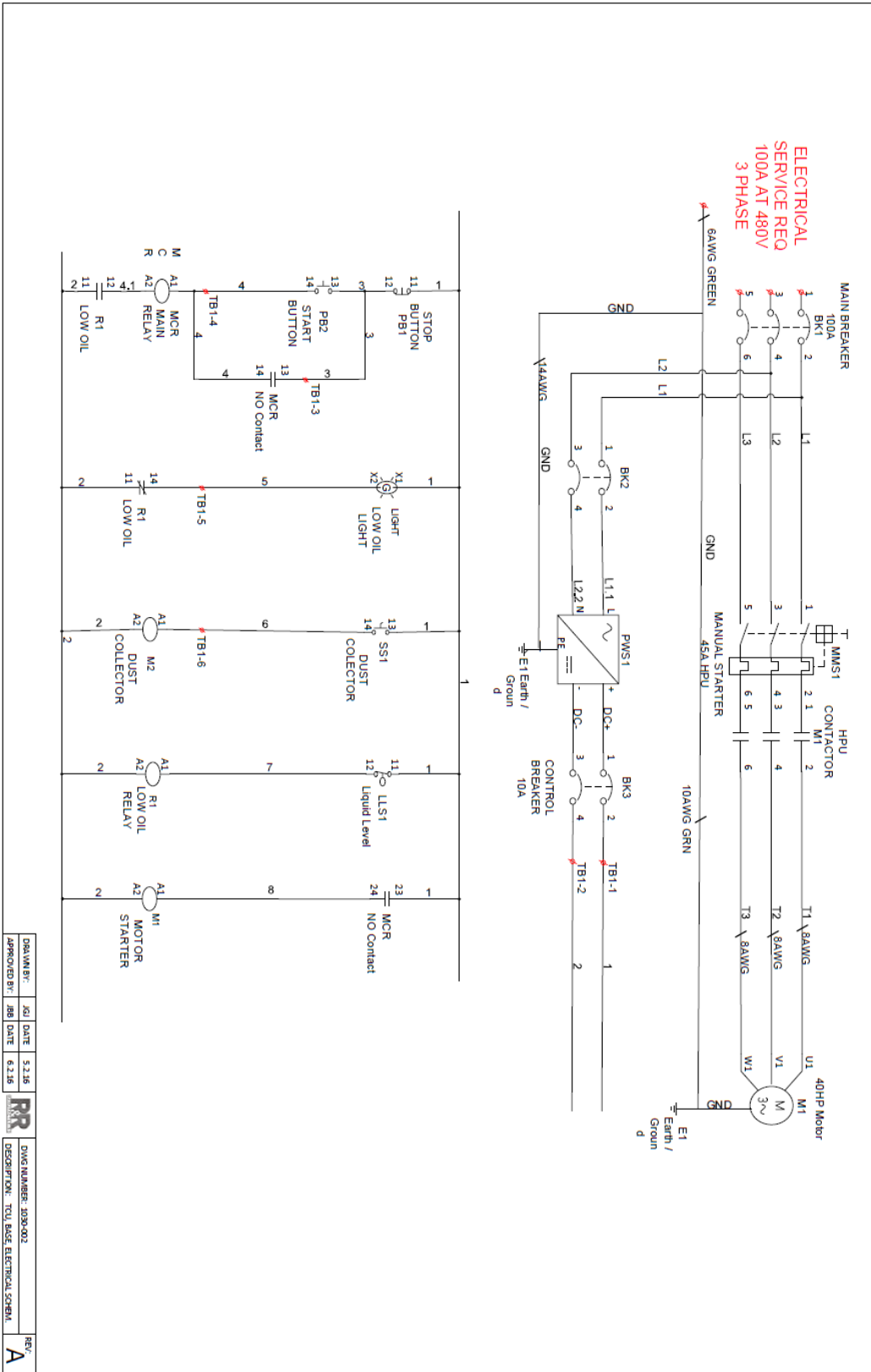

DRAWN BY:	JGI	DATE:	5.3.16	REV:	A
APPROVED BY:	JBI	DATE:	6.3.16	DWG NUMBER: 1030-002	
				DESCRIPTION: TCU BASE ELECTRICAL SCHEM.	